

Shear connector (type SD1 acc. to DIN EN ISO 13918)

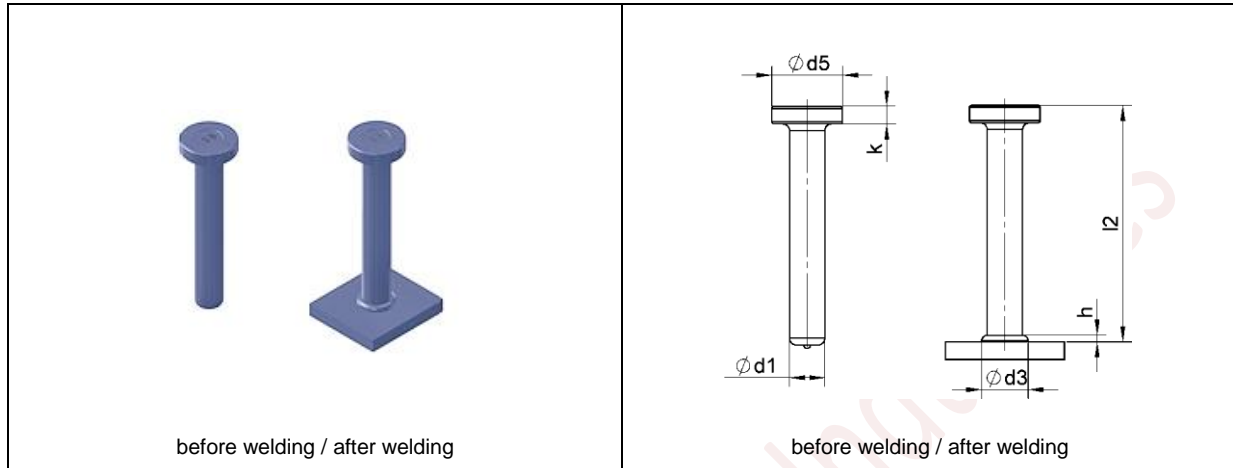

Dimensions					
d1 -0.4/0.4	l2	d5	k	d3*	h*
16	150	32	8	21	4.5
16	175	32	8	21	4.5
16	200	32	8	21	4.5
16	225	32	8	21	4.5
16	250	32	8	21	4.5
16	275	32	8	21	4.5
16	300	32	8	21	4.5
19	50	32	10	23	6
19	60	32	10	23	6
19	75	32	10	23	6
19	80	32	10	23	6
19	90	32	10	23	6
19	100	32	10	23	6
19	125	32	10	23	6
19	150	32	10	23	6
19	175	32	10	23	6
19	200	32	10	23	6
19	225	32	10	23	6
19	250	32	10	23	6
19	275	32	10	23	6
19	300	32	10	23	6

22	75	35	10	29	6
22	90	35	10	29	6
22	100	35	10	29	6
22	125	35	10	29	6
22	150	35	10	29	6
22	175	35	10	29	6
22	200	35	10	29	6
22	225	35	10	29	6
22	250	35	10	29	6
22	275	35	10	29	6
22	300	35	10	29	6
25	75	41	12	31	7
25	100	41	12	31	7
25	125	41	12	31	7
25	150	41	12	31	7
25	175	41	12	31	7
25	200	41	12	31	7
25	225	41	12	31	7
25	250	41	12	31	7
25	275	41	12	31	7
25	300	41	12	31	7

*d3 and h are approximate values.